

®

**ROBERTO**

***Pompe per vuoto  
ad anello liquido***

***Liquid ring  
vacuum pumps***

***nuova serie  
new series***





RVS 3/M

Le pompe per vuoto RVS sono pompe ad anello liquido monostadio con le seguenti caratteristiche:

- pressioni di aspirazione fino a 33 mbar abs;
- portate fino a 4200 m<sup>3</sup>/h;
- possibilità di aspirare gas e vapori, anche in presenza di liquido trascinato;
- compressione dei gas praticamente isoterma;
- gas aspirato non inquinato da lubrificanti;
- esercizio affidabile e manutenzione minima;
- rumore e vibrazioni contenuti;
- ampio campo di impiego grazie alla gamma di materiali di costruzione.

*RVS liquid ring vacuum pumps are a single stage block model with following features:*

- vacuum pressure up to 33 mbar abs;
- suction capacity up to 4200 cu.m/h;
- able to pump gases and vapours;
- able to handle liquid together with gas;
- nearly isothermal compression of gases;
- no lubricant in contact with pumped gases;
- safe operation and minimum maintenance;
- reduced noise and vibration;
- can be used for different applications with proper selection of construction materials and service fluid.



RVS 21/SG

### CAMPI DI IMPIEGO

Le pompe RVS si impiegano per aspirare gas e vapori nei diversi settori dell'industria chimica, farmaceutica, alimentare, ospedaliera, cartaria, saccarifera, tessile ed energetica, in processi di sterilizzazione in autoclave, concentrazione, essiccazione, impregnazione, estrusione di materie plastiche, degasaggio ed estrazione di incondensabili da condensatori.

### FIELDS OF APPLICATION

*The RVS pumps are suitable to compress gas and vapours in the process of sterilization, concentration, drying, impregnation, plastic extrusion, degassing and extraction of non-condensable gas from condensers in the chemical, pharmaceutical, food, pulp and paper, sugar, textile, in power plant industry and in hospitals.*

### CARATTERISTICHE COSTRUTTIVE

- Nuova piastra di distribuzione brevettata in lamiera di acciaio inox tagliata al laser.
- Nuovo supporto per la versione /SG intercambiabile con la serie RMV.

### DESIGN FEATURES

- New patented, laser cut, stainless steel distribution plate.
- New bearing bracket for /SG version interchangeable with RMV pump type.



RVS 25/CT

### Sopportazione

Le pompe /M (grandezze 3+16) sono montate direttamente su albero e flangia del motore elettrico.

Le pompe /SG (grandezze 7+21) sono montate a sbalzo su un supporto con cuscinetti schermati e lubrificati a vita con grasso.

Le pompe delle grandezze 23+60 hanno due supporti con cuscinetti lubrificati a grasso (schermati e lubrificati a vita per 23-25).

### Bearing bracket

*The pumps of the type /M (sizes 3+16) are directly coupled to the flange of an electric motor and the impeller is supported by the electric motor standard bearings. The pumps of the type /SG (sizes 7+21) are supported by a bearing bracket with two sealed bearings life lubricated with grease. The vacuum pumps sizes 23+60 have two bearing brackets with bearings grease lubricated (sealed and life lubricated for sizes 23-25).*

### Tenuta sull'albero

Fino alla grandezza 25 sono montate tenute meccaniche singole normalizzate EN 12756 (ex. DIN24960) flussate dal liquido di servizio.

Le grandezze 30-60 montano di serie tenute a baderna (su richiesta tenute meccaniche singole o doppie) flussate dal liquido di servizio.

L'albero non è a contatto con il liquido ed i gas convogliati (ad esclusione delle 23-25).

### Drive shaft seals

*Up to size 25 the shaft is sealed by single mechanical seals according to EN 12756 (ex. DIN24960), flushed by service liquid. The shaft of sizes 30-60 is sealed by soft packing seal flushed with service liquid in the standard design. Single or double mechanical seals flushed from external source are available upon request. The shaft is not in contact with pumped liquids or gases (excluded sizes 23-25).*



RVS 40/CT

### Note di funzionamento

Durante l'utilizzo la pompa deve essere continuamente alimentata con liquido di servizio, normalmente acqua (ma è possibile impiegare anche olii, solventi, ecc.), per smaltire il calore generato dalla compressione del gas e rimpiazzare il liquido di servizio che esce dalla pompa assieme al gas. Il liquido di servizio scaricato può essere separato dal gas in un separatore e riutilizzato parzialmente o totalmente previo raffreddamento.

### Note

*The pump must be continuously fed with service liquid, normally water (oils, organic liquids, etc. can also be used), while working in a sufficient rate to eliminate the heat produced by the compression of gases and to replace any liquid which flows out of the pump together with the gas. The service liquid can be separated from the gas in a liquid separator and can be recirculated either partially or entirely, after intermediate cooling. Under difficult working conditions, a device can be installed for to reduce the cavitation problem.*



RVS 60/CT

Per condizioni di funzionamento gravose, si può installare un dispositivo che riduce sensibilmente i problemi di cavitazione.

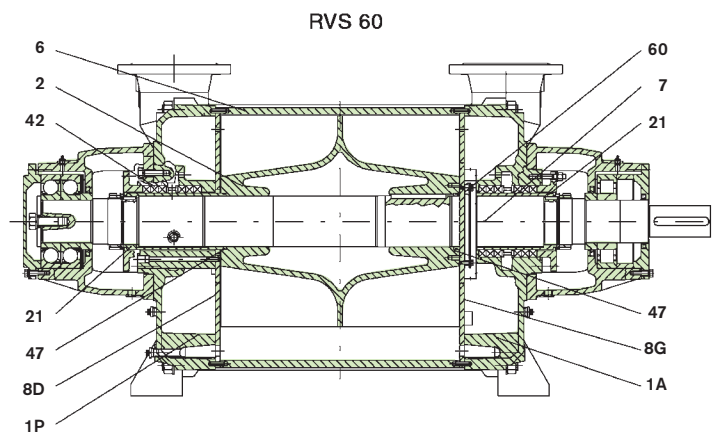
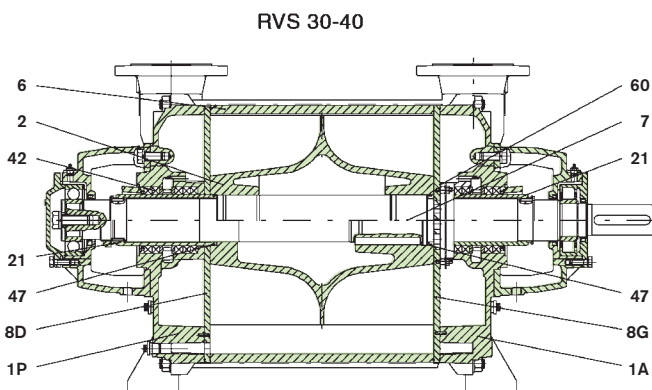
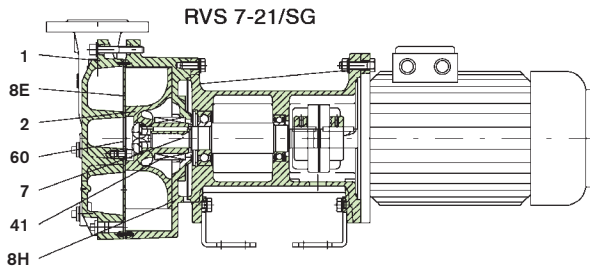
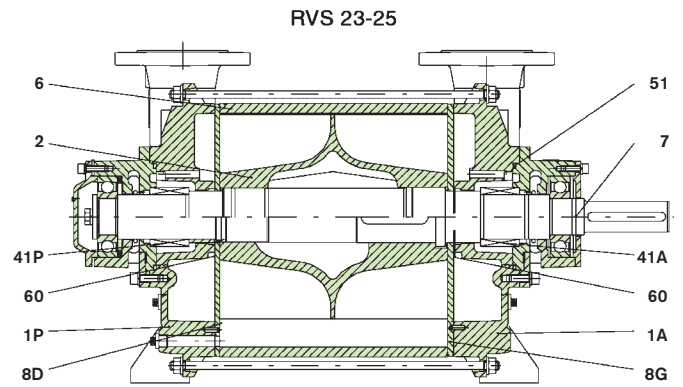
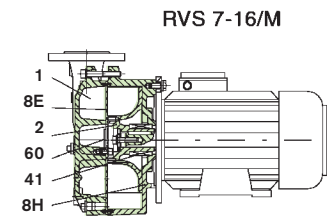
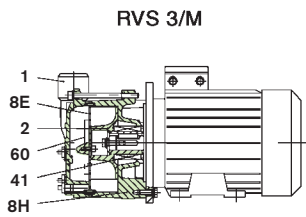

POS.	PARTICOLARE - COMPONENT	NORME NORMS	ESECUZIONE MATERIALI - MATERIAL DESIGN				
			02 <sup>(1)</sup>	09 <sup>(2)</sup>	24 <sup>(2)</sup>	06 <sup>(2)</sup>	
1 - 1A/P	Corpo - Body	UNI-EN	G250 UNI EN 1561		GX6CrNiMo2011 UNI EN 10213-4		
		ASTM	A48 No. 35 A		A351 CF8M		
2	Girante - Impeller	UNI-EN	G-CuSn5Zn5Pb5 UNI EN 1982	GS400-15 UNI EN 1563	GX6CrNiMo2011 UNI EN 10213-4		
		ASTM		A536-84 GR 60-40-18	A351 CF8M		
6	Elemento - Casing	UNI-EN	-	Fe510 UNI EN 10297-1	X5CrNiMo1712 UNI EN 10088-3		
		ASTM	-	A 501	A276 316		
7	Albero - Shaft	RVS 7+21	UNI-EN	-	C40 UNI EN 10083-1		
			ASTM	-	A576 GR 1040		
		RVS 23-25	UNI-EN	-	X30Cr13 UNI EN 10088-3	X5CrNiMo1712 UNI EN 10088-3	
			ASTM	-	A276 420	A276 316	
		RVS 30-40-60	UNI-EN	-	C40 UNI EN 10083-1		
			ASTM	-	A576 GR 1040		
8E/G/D	Piastra - Port Plate	UNI-EN	X5CrNiMo1712 UNI EN 10088-3				
		ASTM	A276 316				
8H	Piastra con elemento - Plate with casing	UNI-EN	G250 UNI EN 1561		GX6CrNiMo2011 UNI EN 10213-4		
		ASTM	A48 No. 35 A				
21	Camicia albero - Shaft sleeve	UNI-EN	-	X30Cr13 UNI EN 10088-3	X5CrNiMo1712 UNI EN 10088-3		
		ASTM	-	A276 420	A276 316		
41-41A/P	Tenuta meccanica - Mechanical seal	UNI EN	Grafite-Carbon / SIC / Viton X6CrNiMoTi1713 / X6CrNiMoTi1713 AQ1VGG - EN 12756				
42	Tenuta a baderna - Soft packing seal		Fibra aramidica 40% PTFE / Aramidic fibre 40% PTFE				
47-51	O-rings - O-rings		Viton (Fluorocarbon rubber)				
60	Valvola - Valve		PTFE				
-	Guarnizioni - Seals		Sigillante anaerobico - Anaerobic seal				

(1) Solo per grandezza 3  
(2) Tranne che per grandezza 3

(1) Only for size 3  
(2) Size 3 excluded



## DESIGNAZIONE - DESIGNATION

Pompa per vuoto - Vacuum pump				Gruppo pompa - Pump package				Unità per vuoto - Vacuum unit			
RVS <b>16</b> / <b>SG</b> - <b>09</b>				<b>L</b> RVS <b>30</b> / <b>CT</b> - <b>06</b>				KRVS <b>14</b> / <b>SG</b> / <b>T</b> - <b>06</b>			
GRANDEZZA SIZE 3+40				SERIE SERIES C GIUNTO COUPLING L CINGHIE BASCULANTE V-BELT SELF TENSIONING				GRANDEZZA SIZE 7+40			
VERSIONE VERSION M MONOBLOCCO 3+16 CLOSE COUPLED SG SOPPORTO 7+21 BRACKET CT COLLETTORI 23+60 MANIFOLDS CR SEPARATORE 23+40 SEPARATOR				GRANDEZZA POMPA PUMP SIZE 23+60				VERSIONE POMPA PUMP VERSION M MONOBLOCCO 7+16 CLOSE COUPLED SG SOPPORTO 7+21 BRACKET CT COLLETTORI 23+60 MANIFOLD			
ESECUZIONE EXECUTION 02 09 24 06				VERSIONE POMPA PUMP VERSION CT COLLETTORI 23+60 MANIFOLD CR SEPARATORE 23+40 SEPARATOR				VERSIONE UNITÀ UNIT VERSION P RICIRCOLO PARZIALE PARTIAL RECIRCULATION T RICIRCOLO TOTALE TOTAL RECIRCULATION			
				ESECUZIONE POMPA PUMP EXECUTION 09 24 06				ESECUZIONE POMPA PUMP EXECUTION 09 24 06			

## DATI TECNICI - TECHNICAL DATA

			RVS3	RVS7	RVS14	RVS16	RVS17	RVS21	RVS23	RVS25	RVS30	RVS40	RVS60	
			Velocità di rotazione pompa Pump rotation speed	50 Hz 60 Hz	rpm	2850 3420				1450 1750				970 1170
Potenza installata (1) Motor power (1)	50 Hz 60 Hz	kW	1,5 2,2	3 4	4 5,5	5,5 7,5	7,5 11	11 15	15 18,5	22 30	30 37	45 55	90 127	
Pressione di aspirazione minima Min suction pressure		mbar	33											
Max sovrappressione di scarico /M Max discharge overpressure /SG		mbar	100 -		100 200		- 200		200		300			
Max temperatura gas aspirato Max temperature of gas		°C	100											
Max temperatura liquido di servizio Max temperature of service liquid		°C	70											
Max viscosità liquido di servizio Max viscosity of service liquid		mm <sup>2</sup> /s	8						20					
Q.tà di liquido alla mezzzeria della pompa Contents of liquid in the pump up to shaft level		l	0,25	1,1	1,5	2,3	3	4	6	8	15	24	95	
Momento d'inerzia parti rotanti Inertia moment of rotation parts		kg m <sup>2</sup>	0,004	0,05	0,06	0,11	0,15	0,23	0,33	0,51	2,16	3,33	8,5	
Rumorosità ad 80 mbar (2) Noise level at 80 mbar		dB(A) ±3	72						74	76	78	79	82	

(1) Motori di grandezza superiore possono essere installati a richiesta (fino alla grandezza 21 solo per la versione /SG).

(1) Bigger motor sizes can be installed under request (until size 21 only for the /SG pump).

(2) Escluso rumore di scarico.

(2) Discharge noise excluded.

## ALIMENTAZIONE LIQUIDO DI SERVIZIO - SERVICE LIQUID FLOW

La portata di liquido di servizio nel caso di aspirazione di aria secca, in funzione della pressione di aspirazione e della differenza di temperatura, è data dalla tabella seguente (espressa in m<sup>3</sup>/h).

The service fluid flow when pumping dry air, dependant on suction pressure and temperature difference, is shown in the following table (cu.m/h).

Pompa Pump	Hz	Pressione di aspirazione - Suction pressure									
		33 ÷ 200 mbar		200 ÷ 600 mbar				> 600 mbar			
		LP	RP	LP	RP	LP	RP	LP	RP		
3	50	0.48	0.18	0.11	0.42	0.16	0.10	0.36	0.14	0.09	
	60	0.62	0.24	0.14	0.55	0.21	0.13	0.47	0.18	0.10	
7-14	50	0.80	0.30	0.18	0.72	0.27	0.17	0.60	0.22	0.14	
	60	0.95	0.36	0.22	0.86	0.32	0.20	0.72	0.27	0.17	
16-17-21	50	1.15	0.43	0.27	0.95	0.36	0.22	0.85	0.32	0.20	
	60	1.40	0.53	0.32	1.15	0.43	0.27	1.00	0.38	0.23	

Pompa Pump	Hz	Pressione di aspirazione - Suction pressure									
		33 ÷ 200 mbar		200 ÷ 600 mbar				> 600 mbar			
		LP	RP	LP	RP	LP	RP	LP	RP		
23	50	2.00	1.00	0.70	1.80	1.00	0.70	1.50	0.88	0.63	
	60	2.40	1.20	0.84	2.16	1.20	0.84	1.80	1.05	0.75	
25	50	2.60	1.41	0.97	2.30	1.37	0.98	2.10	1.25	0.89	
	60	3.12	1.70	1.16	2.76	1.64	1.17	2.52	1.50	1.07	
30	50	5.10	2.10	1.32	3.90	2.05	1.39	3.30	1.78	1.22	
	60	6.12	2.52	1.58	4.68	2.46	1.66	3.96	2.13	1.46	
40	50	6.00	2.85	1.87	4.70	2.78	1.97	4.20	2.55	1.83	
	60	7.20	3.45	2.24	5.60	3.33	2.36	5.00	3.06	2.19	
60	50	11.00	5.23	3.42	8.85	5.20	3.71	5.10	3.10	2.21	
	60	13.00	6.20	4.00	10.50	6.17	4.41	5.55	3.47	2.33	

LP = Funzionamento con liquido di servizio fresco (a perdere).

RP = Funzionamento con liquido di servizio combinato, con differenza di temperatura fra liquido fresco e liquido ricircolato rispettivamente di 5 e 10° C.

LP = Using fresh service liquid.

RP = Using mixed service liquid with temperature difference between fresh and recycled liquid of 5 and 10° C.



**PRESTAZIONI - PERFORMANCES**

GRANDEZZA	Pasp	mbar	33		40		60		80		100		200		400		800	
		torr	25		30		45		60		75		150		300		600	
		inch Hg	1.0		1.2		1.8		2.4		3.0		5.9		11.8		23.6	
SIZE	Hz	50	60	50	60	50	60	50	60	50	60	50	60	50	60	50	60	
3	Qdry	m3/h	10,0	12,0	15,0	18,0	24,0	28,0	28,0	33,0	31,0	36,5	36,0	42,5	39,0	46,5	40,0	47,0
	Qwet	m3/h	19,0	22,0	24,0	29,0	32,0	37,0	34,0	40,0	36,0	42,0	38,0	45,0	40,0	48,0	40,0	47,0
	Na	kW	1,00	1,30	1,00	1,40	1,10	1,60	1,20	1,70	1,25	1,75	1,45	2,05	1,50	2,15	1,25	1,80
7	Qdry	m3/h	40,0	44,0	50,0	58,0	65,0	84,0	73,0	95,0	79,0	103,0	91,0	120,0	99,0	128,5	99,0	130,0
	Qwet	m3/h	77,0	85,0	82,0	96,0	87,0	113,0	90,0	117,0	93,0	121,0	98,0	130,0	103,0	133,0	101,0	132,0
	Na	kW	1,70	2,40	1,80	2,50	2,05	2,80	2,20	3,00	2,30	3,20	2,60	3,80	2,70	3,90	2,50	3,50
14	Qdry	m3/h	58,0	60,0	69,0	75,0	90,0	105,0	100,0	122,0	106,0	132,0	118,0	153,0	123,0	164,5	123,0	169,0
	Qwet	m3/h	109,0	113,0	111,0	121,0	119,0	139,0	122,0	149,0	124,0	154,0	127,0	165,0	127,0	170,0	125,0	172,0
	Na	kW	2,20	3,20	2,40	3,40	2,60	3,70	2,75	4,00	2,90	4,20	3,25	4,60	3,30	4,80	2,95	4,30
16	Qdry	m3/h	94,0	102,0	118,0	130,0	155,0	172,0	175,0	195,0	185,0	209,0	202,0	236,0	203,0	245,0	200,0	240,0
	Qwet	m3/h	184,0	200,0	196,0	216,0	209,0	233,0	217,0	242,0	219,0	247,0	219,0	256,0	211,0	255,0	204,0	245,0
	Na	kW	3,80	5,50	4,00	5,70	4,40	6,20	4,60	6,50	4,80	6,70	5,40	7,30	5,40	7,40	4,70	7,00
17	Qdry	m3/h	110,0	112,0	150,0	160,0	205,0	230,0	225,0	260,0	237,0	278,0	262,0	311,0	270,0	324,0	269,0	320,0
	Qwet	m3/h	207,0	211,0	242,0	258,0	272,0	306,0	275,0	318,0	277,0	325,0	282,0	335,0	280,0	336,0	274,0	326,0
	Na	kW	5,30	7,60	5,40	7,80	5,70	8,20	6,00	8,60	6,40	9,10	7,30	10,40	7,40	10,60	6,40	9,60
21	Qdry	m3/h	150,0	160,0	175,0	190,0	240,0	262,0	275,0	305,0	300,0	335,0	340,0	400,0	370,0	435,0	380,0	455,0
	Qwet	m3/h	269,0	287,0	273,0	296,0	312,0	341,0	332,0	368,0	347,0	387,0	364,0	428,0	382,0	450,0	386,0	462,0
	Na	kW	7,80	11,00	7,90	11,10	8,30	11,70	8,90	12,30	9,20	12,80	10,30	14,40	11,0	14,80	10,30	14,00
23	Qdry	m3/h	180,0	200,0	240,0	272,0	350,0	410,0	410,0	480,0	455,0	520,0	510,0	565,0	525,0	600,0	500,0	605,0
	Qwet	m3/h	347,0	386,0	395,0	450,0	470,0	552,0	506,0	590,0	536,0	613,0	551,0	612,0	546,0	624,0	510,0	617,0
	Na	kW	10,20	12,30	10,50	13,00	11,30	14,50	12,00	15,40	12,50	16,00	14,00	17,20	14,50	17,60	13,80	16,80
25	Qdry	m3/h	370,0	400,0	415,0	500,0	550,0	660,0	648,0	745,0	700,0	790,0	775,0	880,0	775,0	930,0	735,0	950,0
	Qwet	m3/h	673,0	727,0	653,0	787,0	720,0	864,0	785,0	903,0	812,0	917,0	832,0	944,0	802,0	963,0	748,0	966,0
	Na	kW	14,80	17,50	15,00	17,80	16,00	19,30	17,00	20,90	17,80	21,90	20,50	24,80	21,80	26,00	20,00	24,00
30	Qdry	m3/h	450,0	570,0	530,0	710,0	705,0	935,0	820,0	1050,0	890,0	1125,0	1030,0	1255,0	1060,0	1275,0	1050,0	1250,0
	Qwet	m3/h	878,0	1113,0	879,0	1178,0	952,0	1263,0	1016,0	1301,0	1052,0	1330,0	1116,0	1360,0	1103,0	1327,0	1071,0	1275,0
	Na	kW	18,50	28,00	20,00	28,50	22,00	30,00	23,00	31,50	24,00	32,50	27,50	36,00	28,00	36,70	25,00	34,00
40	Qdry	m3/h	875,0	900,0	1010,0	1125,0	1270,0	1450,0	1390,0	1620,0	1460,0	1730,0	1580,0	1950,0	1610,0	1930,0	1540,0	1825,0
	Qwet	m3/h	1617,0	1663,0	1609,0	1792,0	1675,0	1912,0	1693,0	1973,0	1702,0	2017,0	1699,0	2098,0	1669,0	2001,0	1568,0	1858,0
	Na	kW	27,50	39,00	28,00	40,50	31,50	43,00	34,00	45,50	36,50	47,50	42,00	54,00	43,50	57,50	40,00	54,50
60	Qdry	m3/h	1900,0	2279,0	2200,0	2639,0	2634,0	3161,0	2859,0	3431,0	3000,0	3599,0	3300,0	3960,0	3354,0	4025,0	3354,0	4025,0
	Qwet	m3/h	3433,0	4120,0	3448,0	4137,0	3441,0	4129,0	3459,0	4150,0	3477,0	4137,0	3539,0	4247,0	3472,0	4167,0	3413,0	4096,0
	Na	kW	62,00	84,50	63,00	85,70	66,00	89,80	70,50	96,00	75,00	102,0	85,00	115,5	88,50	120,0	81,00	110,0

Pasp = Pressione assoluta di aspirazione  
 Qdry = Portata aria secca a 20°C  
 Qwet = Portata aria saturata a 20°C  
 Na = Potenza assorbita dalla pompa

Pasp = Absolute suction pressure  
 Qdry = Dry air capacity at 20°C  
 Qwet = Saturated air capacity at 20°C  
 Na = Absorbed power

I valori indicati della portata aspirata sono validi per la compressione di aria (rispettivamente secca o saturata) a 20°C dalla pressione di aspirazione fino alla pressione atmosferica (1013 mbar abs) con liquido di servizio a 15°C. La tolleranza delle curve è ±10%. Le prestazioni cambiano per condizioni operative diverse. I principali parametri che influenzano la portata aspirata sono: la densità del gas aspirato, le caratteristiche fisiche del liquido di servizio (tensione di vapore, temperatura, densità, viscosità), la temperatura del liquido di reintegro, la presenza di liquido trascinato dal gas aspirato, pressioni di scarico superiori a quella atmosferica, aspirazione di miscele gas/vapore, velocità di rotazione. In questi casi, per la corretta definizione dei parametri di funzionamento, Vi preghiamo di contattarci.

The values expressed for the suction capacity are valid for the compression of air (respectively dry air or saturated air) at 20°C from suction pressure to atmospheric pressure (1013 mbar abs) using water at 15°C as service liquid. The tolerance of curves is ±10%. Performances change according to operating conditions. The main parameters influencing suction capacity are: density of pumped gas, different physical characteristics of service liquid (vapour pressure, temperature, density, viscosity), integration liquid temperature, presence of liquid entrained along with the gas, discharge pressures above atmospheric pressure, suction of gas/vapour mixture, rotation speed. Should the units be used under non-standard conditions, please contact Robuschi S.p.A. (or an authorized distributor).

## DIMENSIONI D'INGOMBRO - OVERALL DIMENSIONS

### RVS 3 ÷ 16 / M

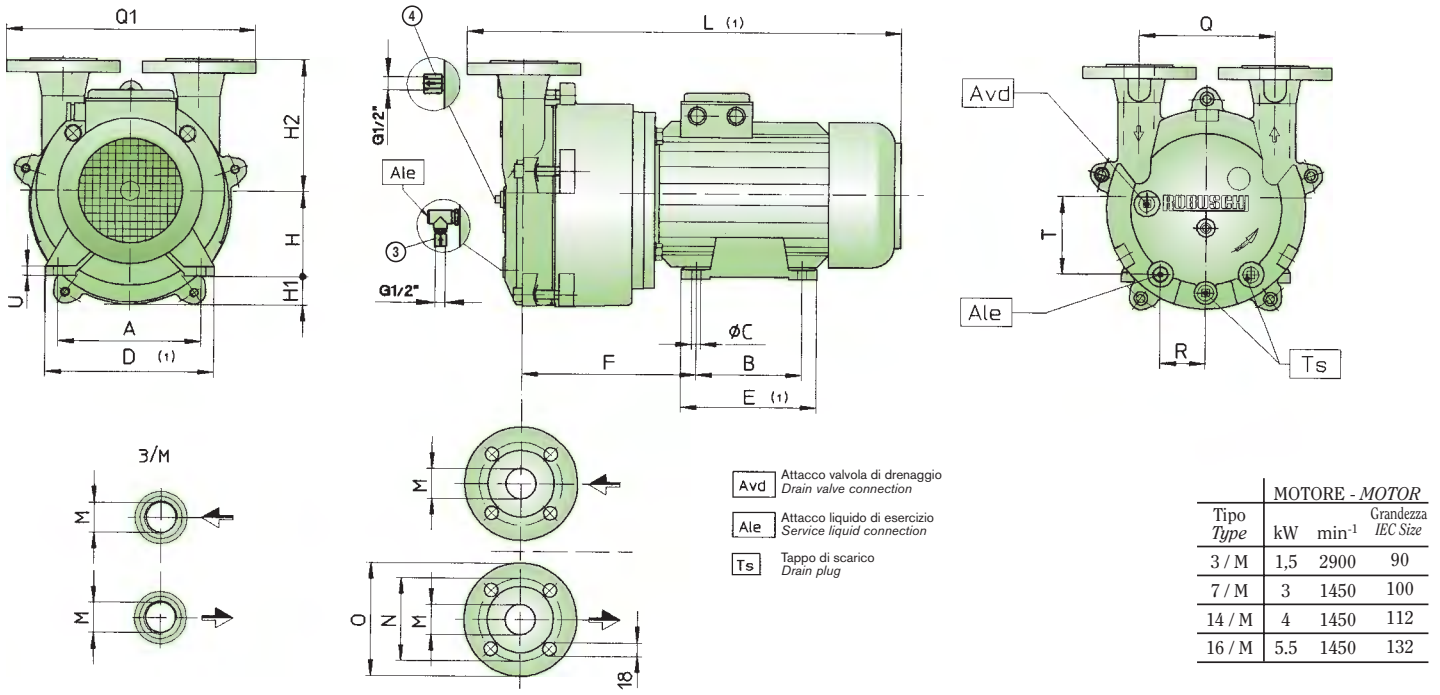

Tipo	A	B	C	D <sup>(1)</sup>	E <sup>(1)</sup>	F	H	H1	H2	L <sup>(1)</sup>	M	N	O	Q	Q1	R	T	U	Ale	Avd	Ts	Massa - Mass <sup>(2)</sup>	
Type											DN inch											kg	
3 / M	140	100	9	174	155	177	90	10	115	425	-	1"	-	-	110	-	31.5	64.5	10	3/8"	3/8"	1/4"	25
7 / M	160	140	12	200	180	200	100	50	174	550	40	1.1/2"	110	150	180	330	50	112	12	1/2"	1/2"	3/8"	63
14 / M	190	140	12	230	180	225	112	38	174	590	40	1.1/2"	110	150	180	330	50	112	12	1/2"	1/2"	3/8"	72
16 / M	216	140	12	260	230	247	132	53	215	660	65	2.1/2"	145	185	200	385	65	138	16	3/4"	1/2"	3/8"	95

### RVS 7 ÷ 21 / SG

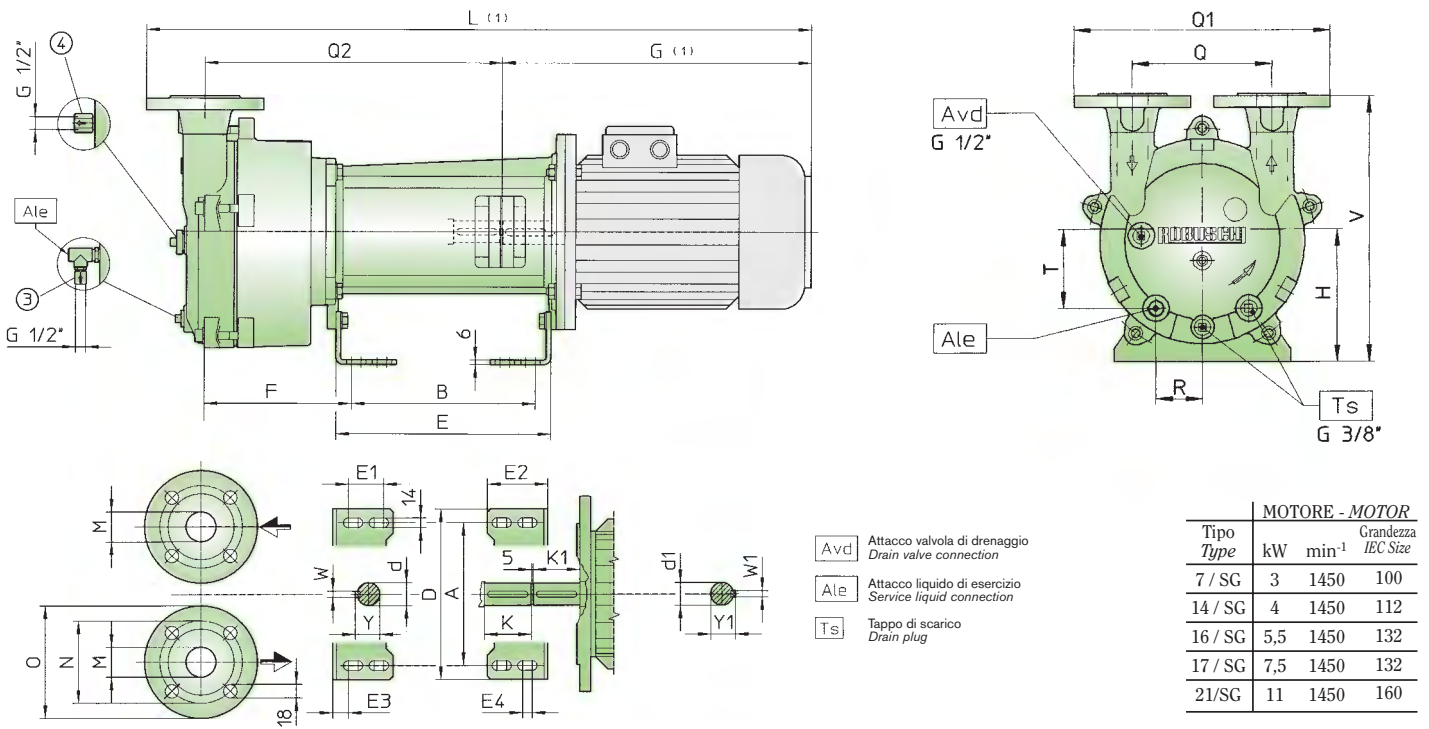

Tipo	A	B	D	E	E1	E2	E3	E4	F	G <sup>(1)</sup>	H	L <sup>(1)</sup>	M	N	O	Q	Q1	Q2	R	T	V	d	K	Y	W	d1	K1	Y1	W1	Ale	Massa - Mass		
Type													DN inch																		kg		
7/SG	190	156	230	214	-	80	29	35	182	400	160	805	40	1.1/2"	110	150	180	330	325	50	112	334	28	43	31	8	28	60	31	8	1/2"	60	96
14/SG	190	156	230	214	-	80	29	35	200	400	160	825	40	1.1/2"	110	150	80	330	343	50	112	334	28	43	31	8	28	60	31	8	1/2"	64	109
16/SG	210	245	250	350	51	122	52.5	15	225	485	192	1045	65	2.1/2"	145	185	200	385	460	65	138	407	38	65	41	10	38	80	41	10	3/4"	93	153
17/SG	210	245	250	350	51	122	52.5	15	257	485	192	1075	65	2.1/2"	145	185	200	385	492	65	138	407	38	65	41	10	38	80	41	10	3/4"	103	176
21/SG	210	245	250	350	51	122	52.5	15	302	650	192	1255	65	2.1/2"	145	185	200	385	506	65	138	407	38	67	41	10	42	110	45	12	3/4"	110	226





LRVS

Nei gruppi LRVS la trasmissione è a cinghie e pulegge ed è basata su di un dispositivo, brevettato, di sospensione oscillante del motore, che consente di ridurre il carico sui cuscinetti della pompa e del motore, di mantenere costante nel tempo la tensione delle cinghie e di adattare facilmente la trasmissione a diverse grandezze di motori senza modificare l'ingombro del gruppo.

Grazie all'accoppiamento a cinghie è possibile selezionare la pompa per vuoto alla velocità ottimale che garantisca la corretta portata necessaria all'impianto senza sprechi di energia e fornire portate fino a 4200 m<sup>3</sup>/h.

*In packages LRVS the power transmission is made with V-belt and pulleys and it is obtained through a patented device rotating around a pivot and supporting the motor in a way which allows to reduce loads on bearings of pump and motor and to keep tension of the belt constant in time. Different motor sizes can be used without modifying overall dimensions of the package.*

*Through V-belt drive vacuum pumps can run at the most suitable speed to obtain the requested capacity for the plant up to the max. capacity of 4200 m<sup>3</sup>/h, without waste of energy.*

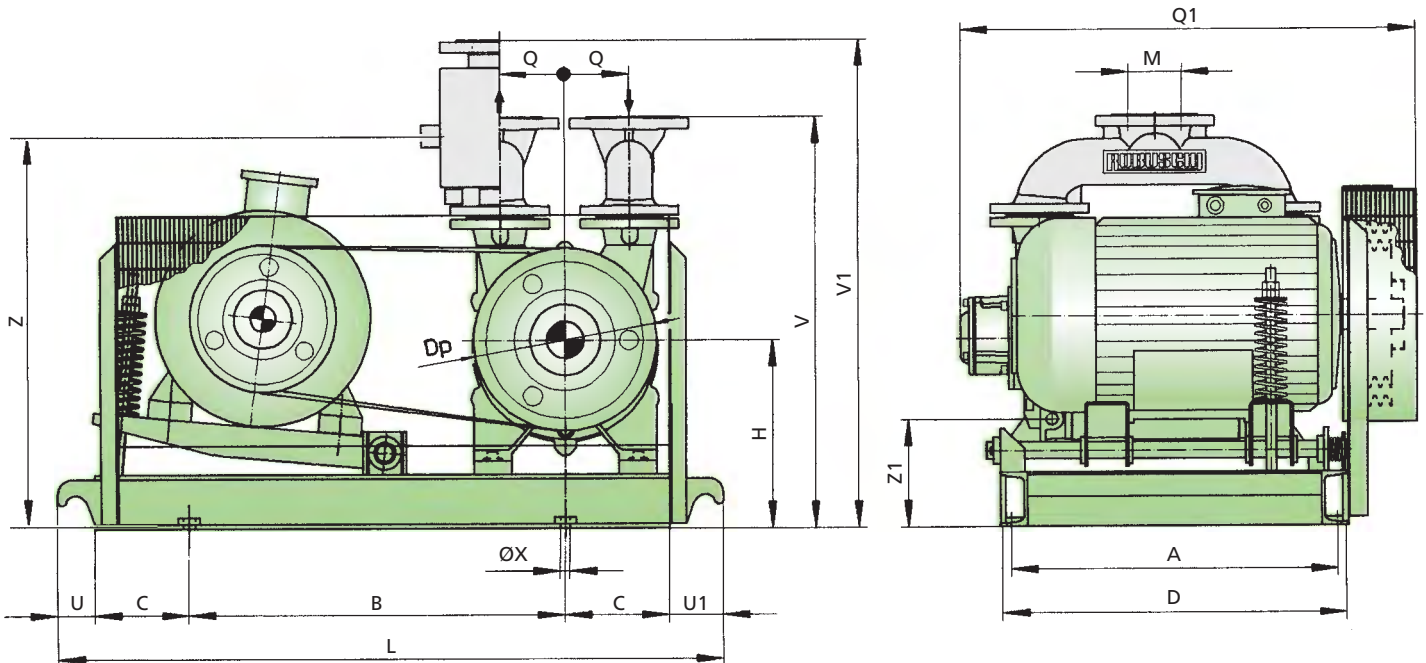
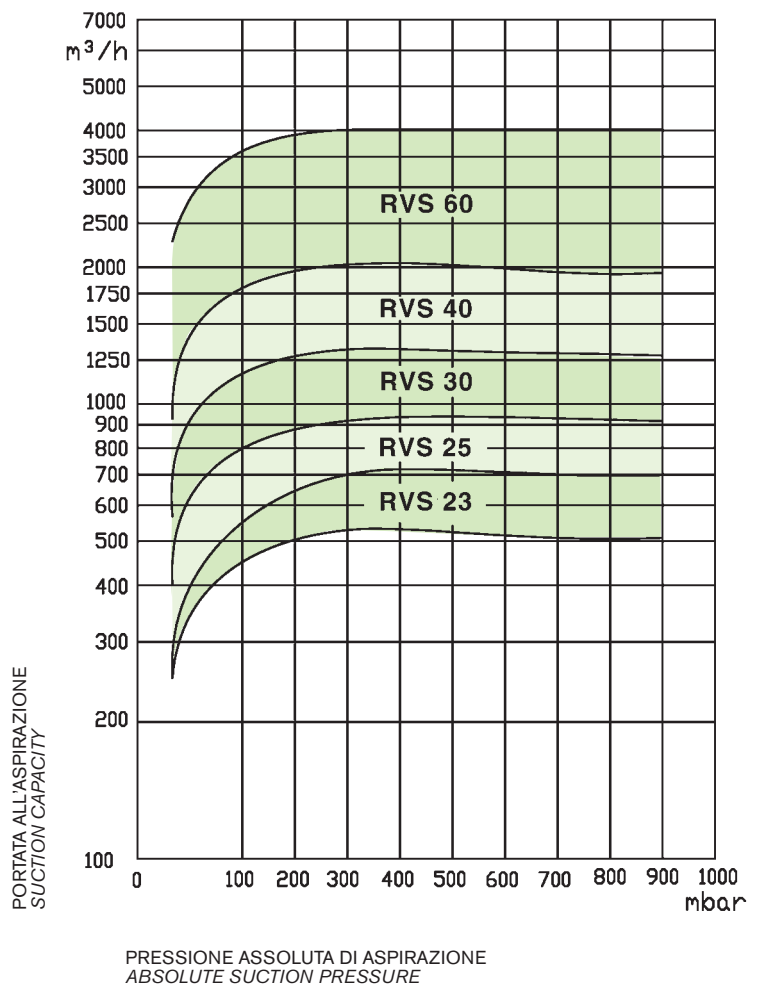

Tipo Type	A	B	C	D	H	L	M	Q	Q1	U	U1	V	V1	ØX	Z	Z1	Dp	Massa Mass kg <sup>(1)</sup>
23	605	700	175	645	350	1221	100	120	730	68	103	761	905	22	727	200	280	242
25	605	700	175	645	350	1221	100	120	835	68	103	761	905	22	727	200	280	282
30	870	1090	255	910	500	1810	125	170	1095	85	125	1010	1275	18	945	275	400	521
40	870	1090	255	910	500	1810	125	170	1235	85	125	1010	1275	18	945	275	400	590
60	1500	1390	255	1500	652	2170	200	254	1875	110	160	1540	1660	22	1255	352	500	1600

(1) Esclusi motore e trasmissione  
(1) Motor and drive excluded

Quote non impegnative in mm  
Not binding dimensions in mm

La Robuschi si riserva di apportare senza preavviso qualsiasi cambiamento rivolto ad un miglioramento dei suoi prodotti

It is policy of Robuschi to always improve its products and the right is reserved to alter specifications at any time without prior notice.



Nei gruppi CRVS la trasmissione avviene mediante giunto elastico e le pompe ruotano alla velocità di sincronismo dei motori elettrici asincroni a 3 fasi.

*In packages CRVS the power transmission is obtained through an elastic coupling and the pumps rotate at the synchronous speed of 3 phase motors.*

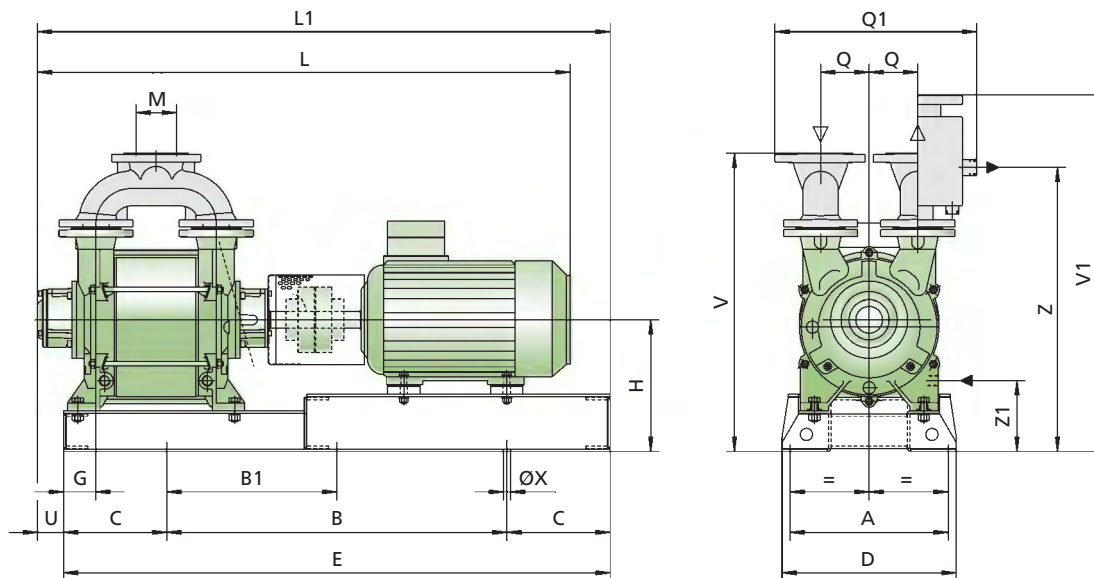

Tipo Type	A	B	B1	C	D	E	F	G	H	L	L1	M	Q	Q1	U	V	V1	ØX	Z	Z1	MOTORE kW	MOTOR min <sup>-1</sup>	Grandezza IEC Size	Massa Mass <sup>(1)</sup> kg
23	390	840	-	255	430	1350	148	80	325	1315	1415	100	120	500	65	736	881	18	701	175	15	1450	160L	312
25	390	840	-	255	430	1350	200	80	325	1520	1415	100	120	500	65	736	881	18	701	175	22	1450	180L	427
30	540	1400	700	250	600	1900	209	105	485	2040	2140	125	170	655	140	997	1260	22	957	260	30	970	225M	863
40	540	1400	700	250	600	1900	279	105	525	2150	2140	125	170	655	140	1037	1300	22	957	300	45	970	280S	1073
60	610	2200	1100	300	680	2800	424	125	712	2927	2850	200	254	910	260	1600	1720	22	1276	412	90	740	315M	2480

(1) Massa indicativa che può variare in funzione della marca del motore. - Not binding mass that can change according to motor make.

**UNITÀ PER VUOTO KRVS**

**KRVS VACUUM UNIT**

I nuovi gruppi Robuschi KRVS sono unità realizzate per la generazione del vuoto nei più svariati settori come quello chimico, petrolchimico, farmaceutico, tessile ecc.

Le unità sono costituite da pompe per vuoto ad anello liquido della serie RVS con serbatoio di separazione per il ricircolo parziale del liquido di servizio e relative tubazioni di collegamento (P); nella versione a ricircolo totale (T) il gruppo è dotato di scambiatore di calore.

Le principali caratteristiche tecniche delle unità sono le seguenti:

- rumore e vibrazioni estremamente contenuti;
- separazione del liquido di esercizio dal gas scaricato;
- liquido di raffreddamento non a contatto con la pompa;
- semplice installazione, avviamento, regolazione e manutenzione.

**PRINCIPALI CARATTERISTICHE COSTRUTTIVE**

**Serbatoio separatore**

Nelle unità KRVS 7+21 la pompa è posizionata sopra al serbatoio separatore che funge così da basamento del gruppo mentre nelle unità KRVS 23+60 il serbatoio è posizionato a lato della pompa.

**Scambiatore di calore (solo per T)**

Il liquido di servizio viene raffreddato mediante uno scambiatore di calore che impedisce il contatto fra fluido di raffreddamento e liquido di servizio, evitando contaminazioni. La temperatura del liquido di servizio si può regolare agendo sulla portata del liquido di raffreddamento.

*The new Robuschi unit KRVS are machines for vacuum generation in different application fields such as chemical, petrochemical, pharmaceutical, textile, ecc.*

*The unit consist of a liquid ring vacuum pump of RVS series complete with separator tank for partial recirculation of service liquid and hose and valves for connections (P); in the total recirculation version (T) the unit is complete with heat exchanger.*

*Main unit features are the following:*

- reduced noise and vibrations;
- separation of service liquid from compressed gas;
- cooling liquid not in contact with the pump;
- easy installation, start-up, setting and maintenance.

**MAIN DESIGN FEATURES**

**Separator tank**

*In the KRVS 7+21 units the pump is positioned on the separator tank which acts as base plate for the unit; in the KRVS 23+60 units the separator tank is positioned aside the pump on the same base plate.*

**Heat exchanger (for T only)**

*Service liquid is cooled through a heat exchanger assuring no contact between cooling and service liquid, avoiding contaminations. Temperature of service liquid is controlled by adjusting flow of cooling liquid*

**MATERIALI - MATERIALS**

POS	PARTICOLARE - COMPONENT	ESECUZIONE MATERIALI - MATERIAL EXECUTION	
1	POMPA - PUMP	09 - 24	06
3	SEPARATORE - SEPARATOR	Fe360 UNI EN 10028-1	X5CrNiMo1712 UNI EN 10088-3
6	SCAMBIATORE (solo KRVS/T) HEAT EXCHANGER (KRVS/T only) Testate - Cover Mantello - Casing Piastre - Plates Tubi - Tubes	G250 UNI EN 1561 C40 UNI EN 10083-1  X5CrNiMo1712 UNI EN 10088-3 X5CrNiMo1712 UNI EN 10088-3	GX6CrNiMo2011 UNI EN 10213-4 X5CrNiMo1712 UNI EN 10088-3
-	TUBAZIONI - PIPING	PVC	

La Robuschi si riserva di apportare senza preavviso qualsiasi cambiamento rivolto ad un miglioramento dei suoi prodotti.

It is policy of Robuschi to always improve its products and the right is reserved to alter specifications at any time without prior notice.

# KRVS 7÷21

Versione /SG - /SG Design

Quote non impegnative in mm - Not binding dimensions in mm

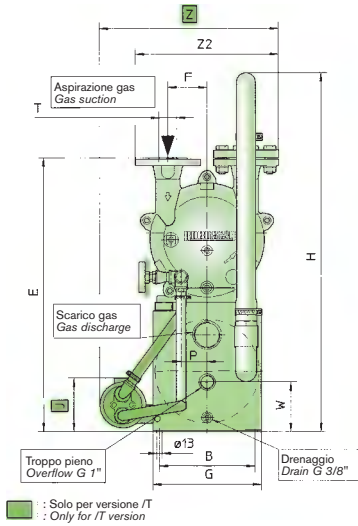

■ : Solo per versione /T  
□ : Only for /T version

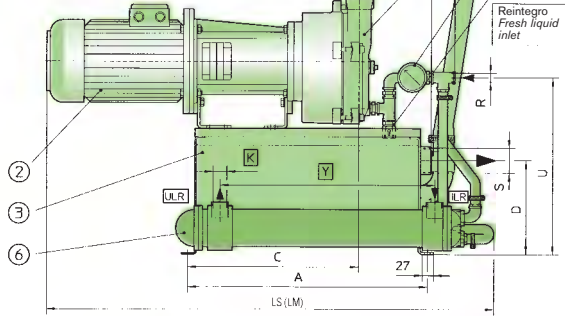
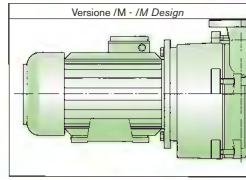

- 1 POMPA RVS/SG - RVS/SG pump
- 2 MOTORE ELETTRICO - Electric motor
- 3 SEPARATORE - Separator tank
- 4 VALVOLE VGB - VGB valves
- 5 TERMOMETRO - Thermometer
- 6 SCAMBIATORE DI CALORE - Heat exchanger

ILR: Ingresso liquido di raffreddamento  
Cooling liquid inlet  
ULR: Uscita liquido di raffreddamento  
Cooling liquid outlet

(1) Quota indicativa che può variare in funzione della marca del motore  
LS Quota con RVS /SG - LM Quota con RVS /M  
(1) Not binding dimension that can change according to motor make  
LS Dimension's for RVS /SG version - LM Dimension's for RVS /M version

Unità Unit																				Massa Mass <sup>(2)</sup>							
	A	B	C	D	E	F	G	H	J	Y	K	LS <sup>(1)</sup>	LM <sup>(1)</sup>	M	P	Q	R	S	T (DN)	U	W	Z	Z2	/P	/T	/P	/T
KRVS 7	572	220	405	224	634	90	250	830	124	400	G 1"	1012	802	175	50	200	G 1/2"	G 2"	40	440	115	413	330	100	115	131	146
KRVS14	572	220	405	224	634	90	250	830	124	643	G 1"	1052	822	175	50	200	G 1/2"	G 2"	40	440	115	413	330	110	125	144	159
KRVS16	942	280	750	270	787	100	310	1020	177	733	G 1"	1310	941	200	65	270	G 3/4"	G 3"	65	540	137	512	385	170	-	228	258
KRVS17	942	280	750	270	787	100	310	1020	177	722	G 1.1/2"	1380	-	200	65	270	G 3/4"	G 3"	65	540	137	512	385	-	-	251	281
KRVS21	942	280	750	270	787	100	310	1020	177	722	G 1.1/2"	1496	-	200	65	270	G 3/4"	G 3"	65	540	137	512	385	-	-	311	341

# KRVS 23÷60

Quote non impegnative in mm - Not binding dimensions in mm

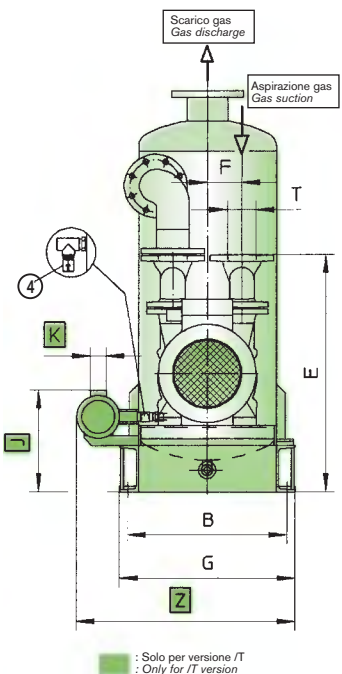

■ : Solo per versione /T  
□ : Only for /T version

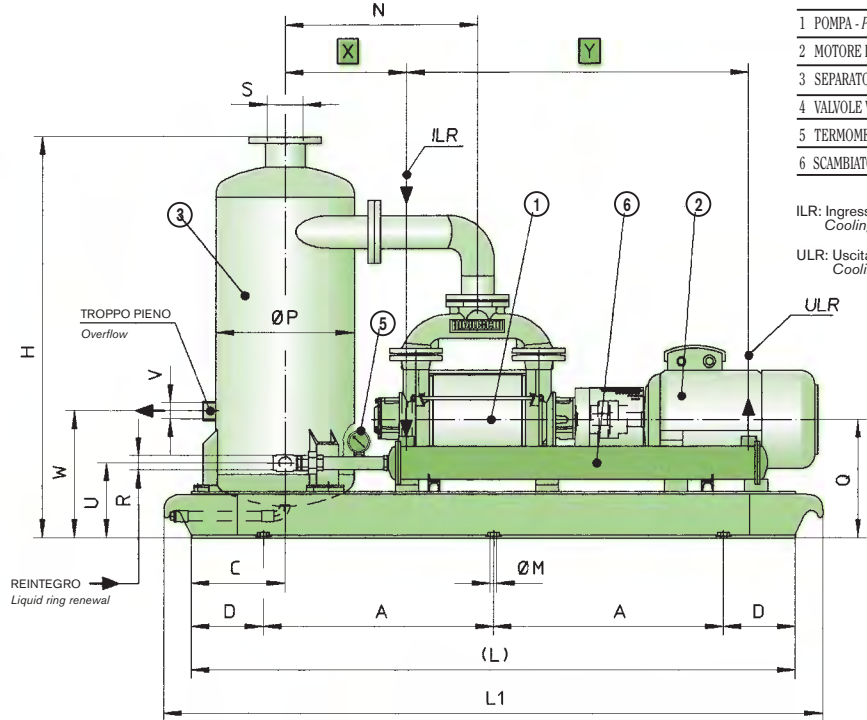

- 1 POMPA - Pump
- 2 MOTORE ELETTRICO - Electric motor
- 3 SEPARATORE - Separator tank
- 4 VALVOLE VGB - VGB valves
- 5 TERMOMETRO - Thermometer
- 6 SCAMBIATORE DI CALORE - Heat exchanger

ILR: Ingresso liquido di raffreddamento  
Cooling liquid inlet  
ULR: Uscita liquido di raffreddamento  
Cooling liquid outlet

Unità Unit																				Massa Mass <sup>(2)</sup>							
	A	B	C	D	E	F	G	H	J	Y	K	L	L1	M	N	X	P	Q	R	S (DN)	T (DN)	U	V	Z	W	/P	/T
KRVS 23	800	555	325	250	821	120	610	1390	352	885	1.1/2"	2100	2290	18	602	495	480	410	1"	125	100	260	2"	815	440	532	580
KRVS 25	800	555	325	250	821	120	610	1390	352	1190	1.1/2"	2100	2290	18	654	495	480	410	1"	125	100	260	2"	815	440	632	680
KRVS 30	1025	640	350	400	1122	170	700	2045	505	1080	2"	2850	3150	20	875	790	600	610	1.1/2"	150	125	385	2.1/2"	940	645	983	1053
KRVS 40	1025	640	350	400	1122	170	700	2045	505	1690	2"	2850	3150	20	945	790	600	610	1.1/2"	150	125	385	2.1/2"	940	645	1185	1255
KRVS 60	1500	790	375	450	1600	254	850	2455	650	1600	2.1/2"	3900	4140	22	1450	1530	700	712	2"	200	200	412	3"	1250	755	2870	3050

(2) Massa comprensiva di motore che può variare in funzione della marca del motore (kg) - Mass including electric motor that can change according to motor make (kg)



### ALIMENTAZIONE LIQUIDO DI SERVIZIO

Per circuito con liquido di servizio a perdere o con ricircolo parziale, il consumo di liquido di servizio è riportato a pag. 4. Per circuito con ricircolo totale del liquido di servizio, la portata dell'acqua di raffreddamento per lo scambiatore è funzione delle condizioni di esercizio del gruppo (temperatura dell'acqua di raffreddamento, pressione di aspirazione, condizioni termofisiche del gas aspirato, ecc.). Nella tabella seguente è riportato indicativamente il consumo di acqua di raffreddamento per due condizioni operative usuali: aria secca ed aria satura a 20°C.

### SERVICE FLUID FLOW

With once-through or partial recirculation circuit, the service liquid flow is related to suction pressure and rotation speed as shown at pag. 4.

With total recirculation circuit, the cooling water flow varies according to unit operating conditions (cooling water temperature, suction pressure, gas characteristics, etc.). In the following table is quoted the flow rate for two common operating conditions: dry air and saturated air at 20°C.

Portata acqua di raffreddamento a 10°C Cooling water flow at 10°C [m³/h]		UNITÀ - UNIT									
		7	14	16	17	21	23	25	30	40	60
Aria secca Dry air	50 Hz	0,45	0,60	0,82	1,13	1,65	2,40	3,60	5,70	7,60	15,20
	60 Hz	0,60	0,83	1,13	1,65	2,26	3,10	4,76	7,45	10,15	20,30
Aria satura Saturated air	50 Hz	0,70	0,93	1,37	1,83	2,64	3,56	5,48	8,46	11,74	23,48
	60 Hz	0,94	1,26	1,76	2,49	3,41	4,50	7,10	11,00	15,00	30,00

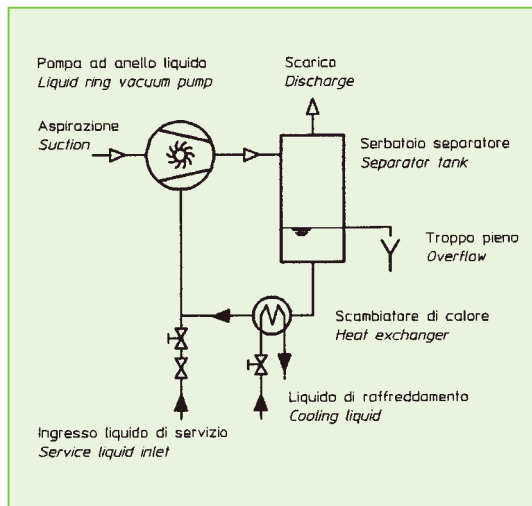



**ROBUSCH<sup>®</sup>**

G E R M A N Y

Ahnser Strasse 5 - 31675 Bückebug - Germany  
Tel. +49 5722 2856-0 - Fax +49 5722 2856-99  
E-mail: robuschi@robuschi.de - www.robuschi.de

**ROBUSCH<sup>®</sup>**

D A N M A R K

Fuglebaekvej 3 A, 1 - 2770 Kastrup - Denmark  
Tel. +45 70257800 - Fax +45 70 257900  
E-mail: sales@robuschi.dk - www.robuschi.dk

**ROBUSCH<sup>®</sup>**

F R A N C E

6, rue de la Grande Borne - 77990 Le Mesnil Amelot - France  
Tel. +33 1 60037569 - Fax +33 1 60037577  
E-mail: robuschi.fr@wanadoo.fr - www.robuschi.fr

**ROBUSCH<sup>®</sup>**

B E N E L U X

Kanaaldijk 100 - 6956 AX Spankeren - Netherlands  
Tel. +31 313 41 5570 - Fax +31 313 41 5433  
E-mail: robuschi@robuschi-benelux.nl - www.robuschi-benelux.nl

**ROBUSCH<sup>®</sup>**

U S A I n c.

3801 Beam Road, Suite F - Charlotte, NC 28217  
Tel: 704-424 1018 - Fax: 704-424 1019 - Toll free: 877-424-1020  
E-mail: sales@robuschiusa.com - www.robuschiusa.com

**ROBUSCH<sup>®</sup>**

C H I N A

218 Tianmu Road West - Suit 1208, Building No. 2, Kerry Everbright City - 200070 Shanghai - China  
Tel. +86 21 6317 5461 / +86 21 6317 6461 - Fax +86 21 6317 7312  
E-mail: robuschichina@robuschichina.com - www.robuschichina.com

**ROBUSCH<sup>®</sup>**

d o B R A S I L

Centro Administrativo Rio Negro - Conjuntos 25 e 26 - Edifício Jaçari - Alameda Rio Negro 585  
CEP 06454-000 - Alphaville/Barueri - SP - Brasil  
Tel +55 11 4191-2322 - Fax +55 11 4191-2277  
E-mail: robuschi@robuschi.com.br - www.robuschi.com.br

**ROBUSCH<sup>®</sup>**

**ROBUSCHI s.p.A.**

**Head office and factory**

Via S. Leonardo, 71/A - 43122 Parma - Italy  
Tel. +39 0521 274911/91 - Fax +39 0521 771242  
E-mail: robuschi@robuschi.it - www.robuschi.com

**FILIALE DI MILANO**

Via XXV Aprile, 2 - 20097 S. Donato (Milano) - Italy  
Tel. +39 02 51628065 - Fax +39 02 51620224  
E-mail: robuschimi@robuschi.it

**FILIALE DI PADOVA**

Piazza Zanellato,5 - 35129 Padova - Italy  
Tel. +39.049.8078260 - Fax +39.049.8078183  
E-mail: robuschird@robuschi.it

V7-1A07C

