



ABS SUBMERSIBLE RECIRCULATION PUMP RCP

- ❑ **Compact design**
- ❑ **Maintenance friendly**
- ❑ **Very good hydraulic efficiencies**
- ❑ **High operation reliability**
- ❑ **Simple installation**

Application areas

The ABS submersible recirculation pumps RCP have been designed for pumping activated sludge in treatment plants during the nitrification and denitrification process, as well as for pumping of storm, surface and river water. As all ABS submersible pumps and submersible mixers they have been designed for economical and reliable operation.

Installation

The ABS submersible recirculation pumps RCP are supplied with the well-proven automatic coupling system using a single guide rail. The ABS single guide rail coupling system guarantees quick and economical installation.

The DIN-flange of the discharge line (supplied by the customer) forms the connection flange of the ABS automatic coupling unit. A guide rail joins the connection flange with the pipe retainer at the top of the tank. The RCP is connected on to the guide rail and can be lowered easily. It reaches its correct operating position automatically and is immediately ready for use.

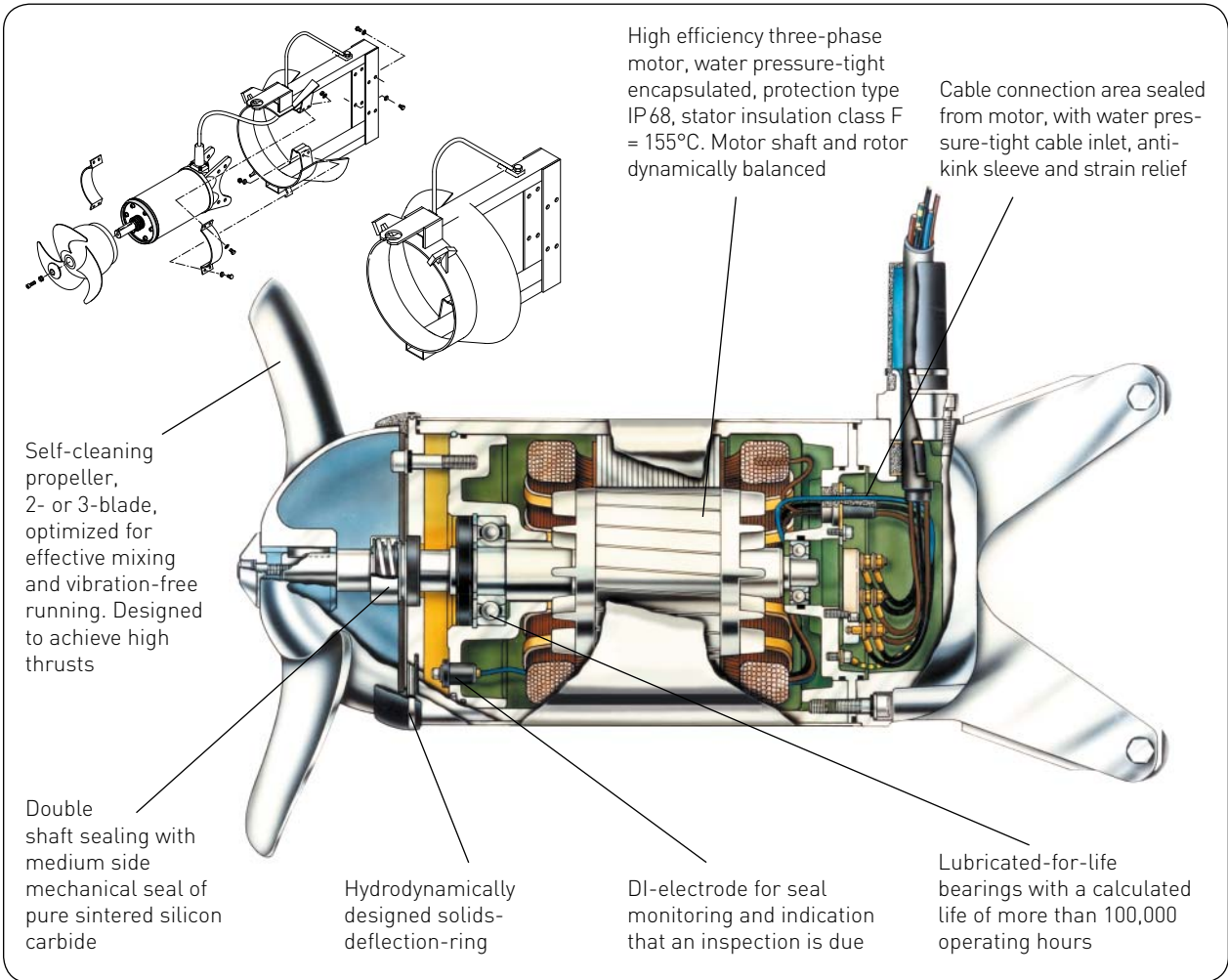

Installation example

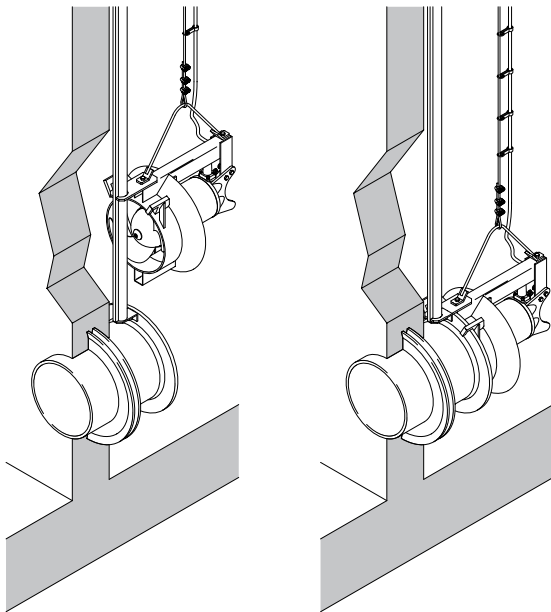

Technical specifications

Pipe diameter:	DN 250 to DN 800
Motor power:	1.5 - 25 kW
Flow max:	up to 1,200 l/s
Head:	up to 2.3 m

Construction

Available in two standard material versions:

EC Cast iron version (EConomical)

Motor housing and bracket made of GG-25/GGG-40, propeller and fasteners made of stainless steel.

CR Stainless steel version (Corrosion Resistant)

Motor housing (RCP 800 = 1.4408) and propeller made of 1.4571 stainless steel, bracket made of 1.4408 and fasteners made of 1.4401 stainless steel.

Performance curves

